

82090

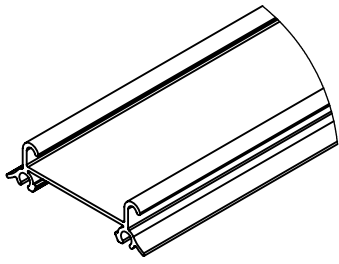

8840

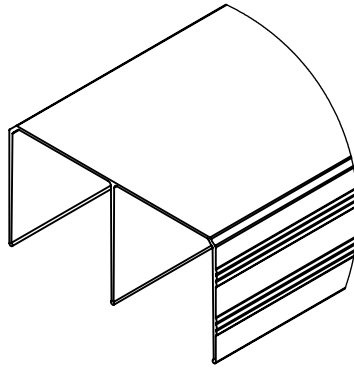

8203

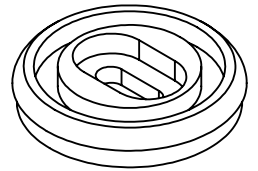

8660 x4

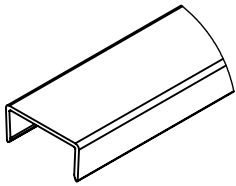

8160 x2

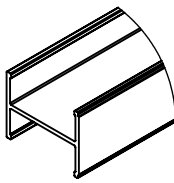

87200 x4

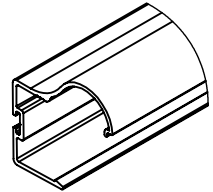

8896 x4

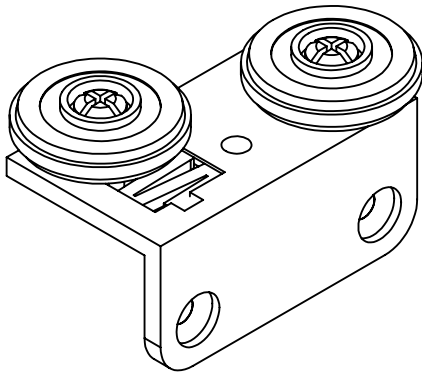

8800 x4

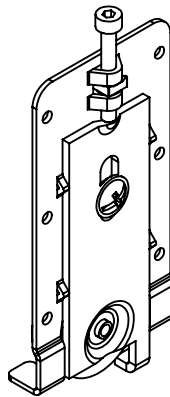

UW 4x16 x4

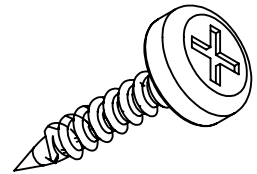

UW 3x10 x24

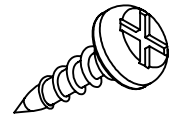

8802 x2

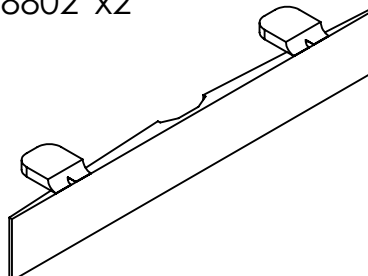

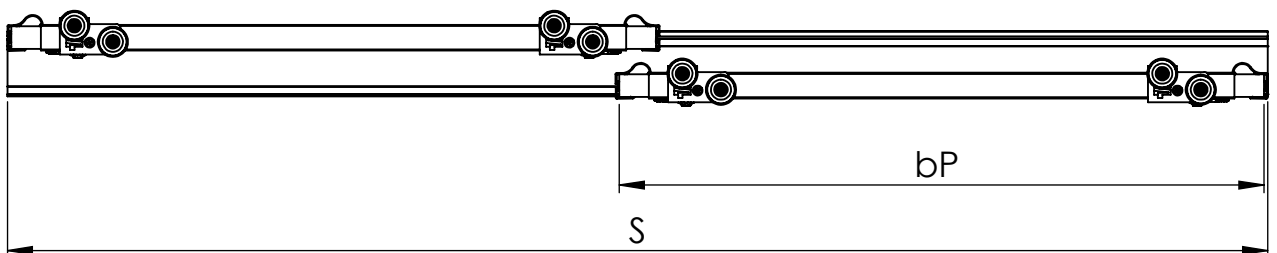
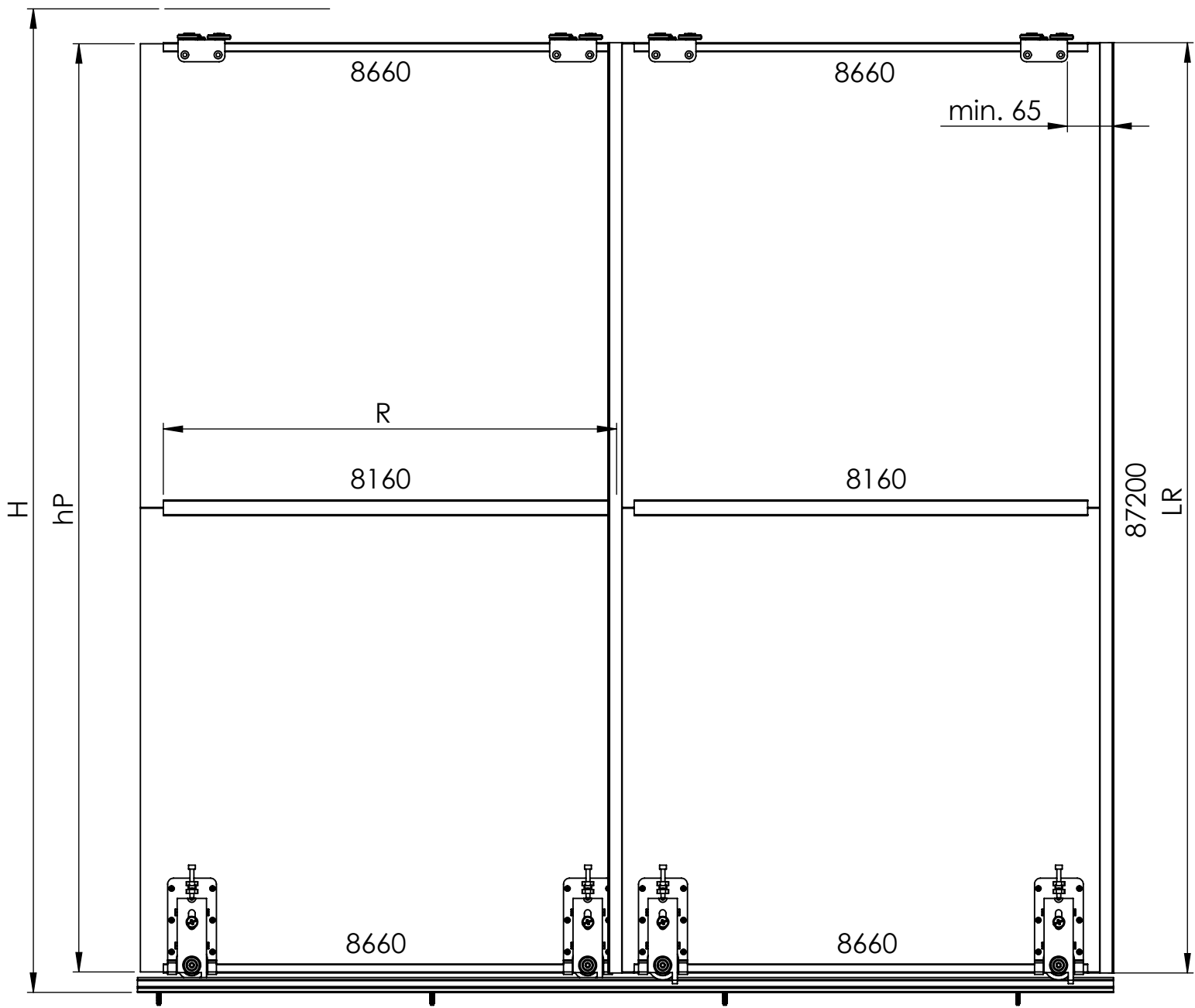

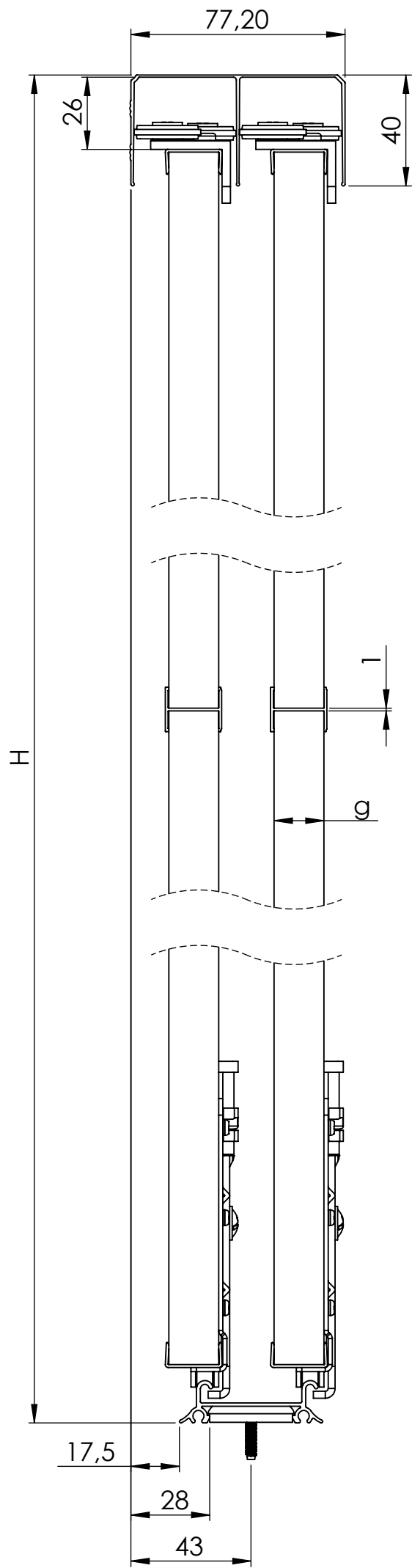

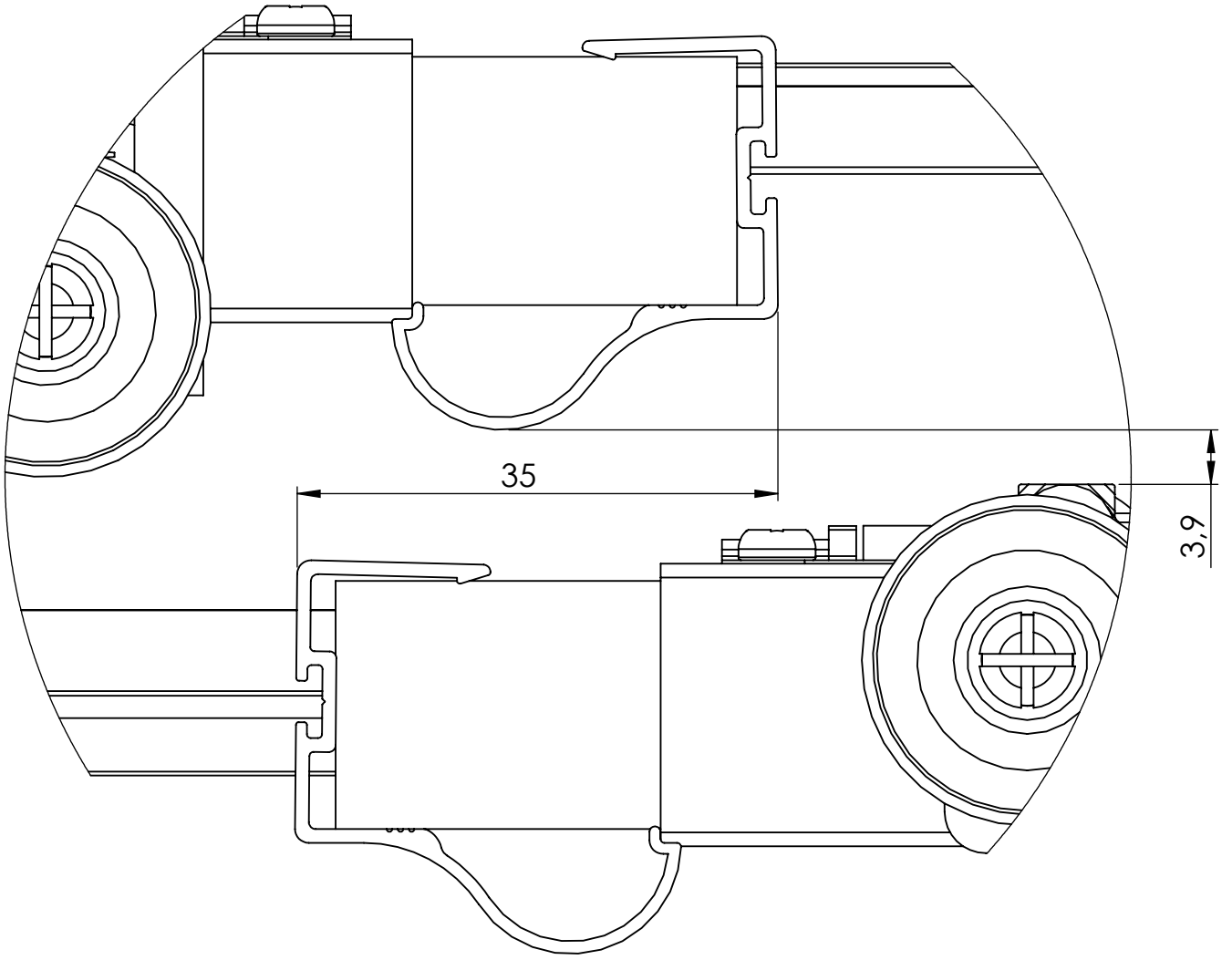

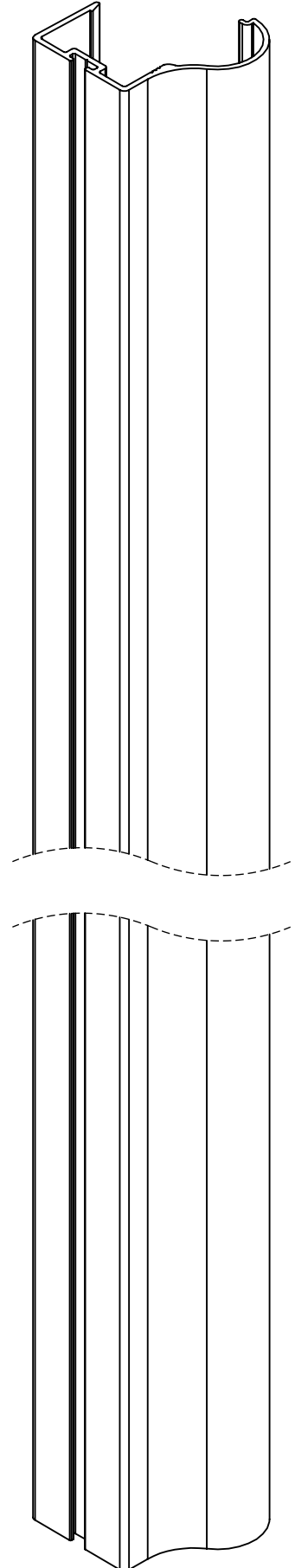
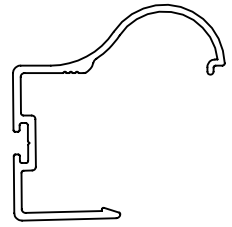

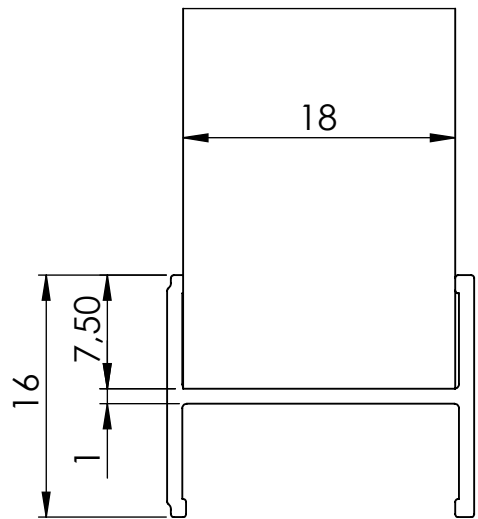
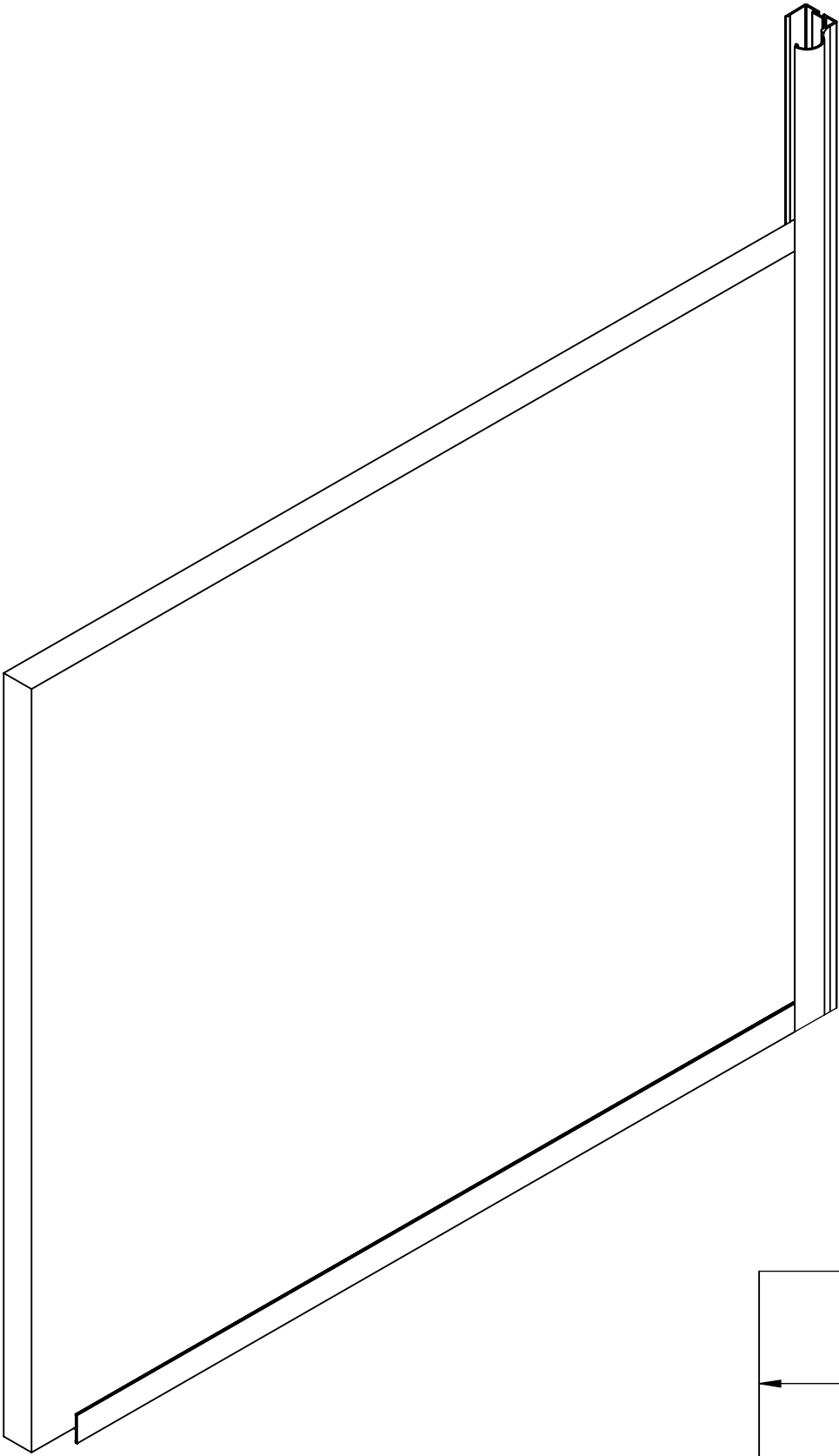

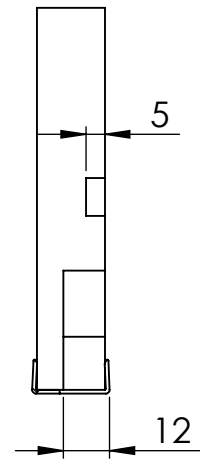
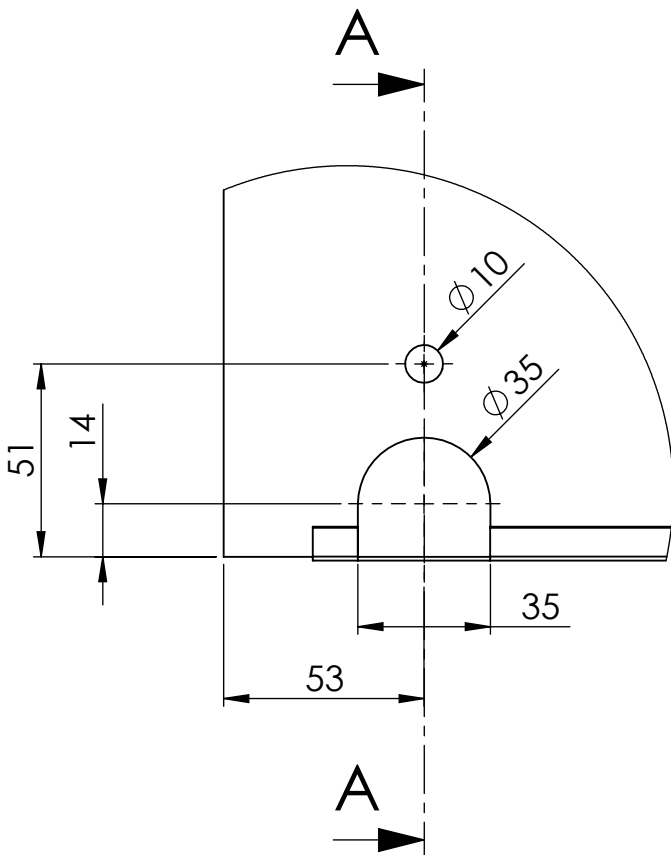
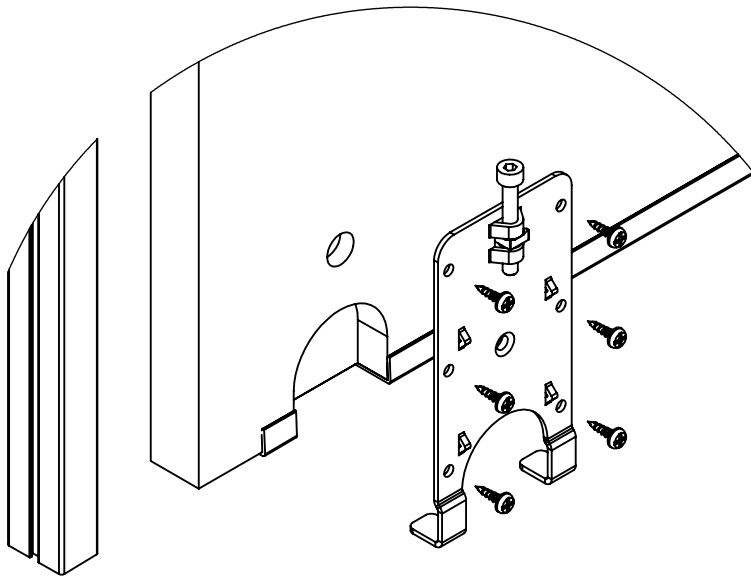

SECTION A-A

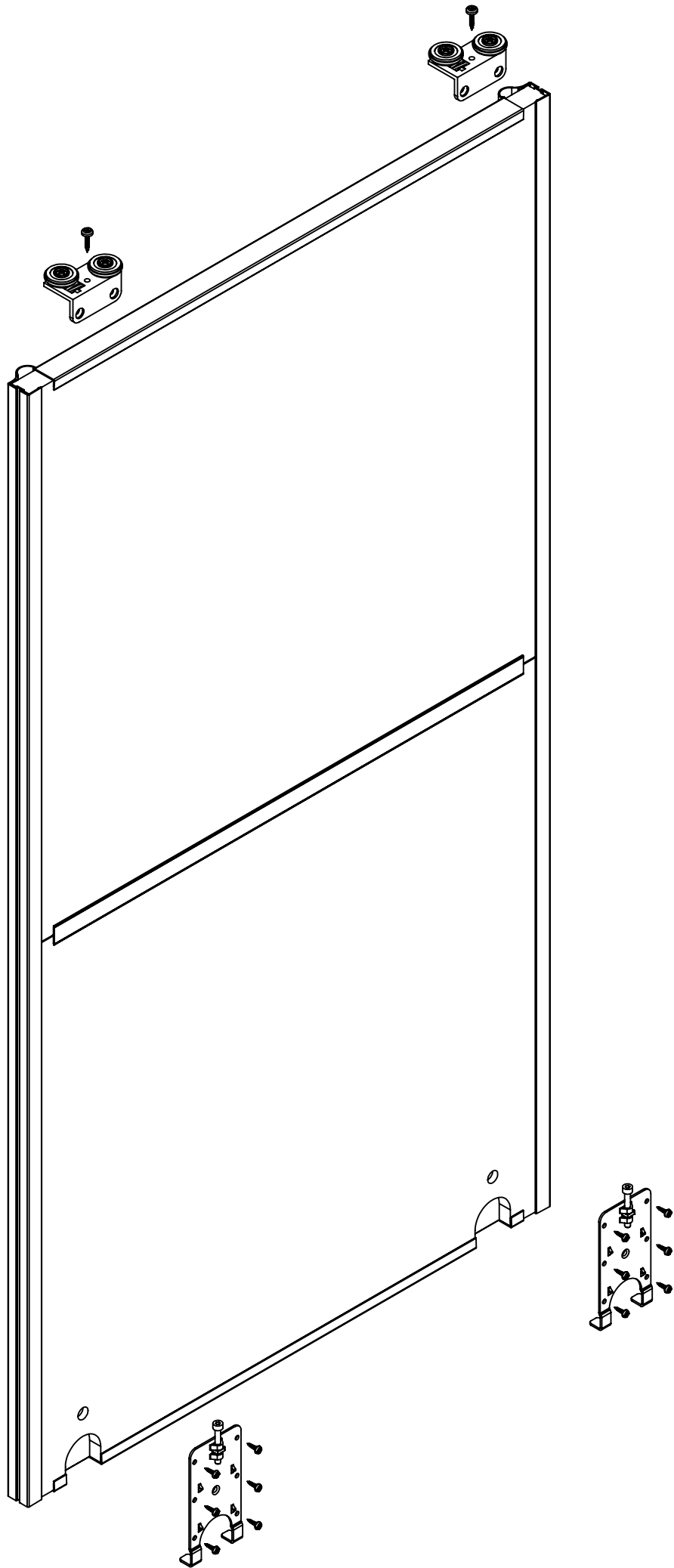

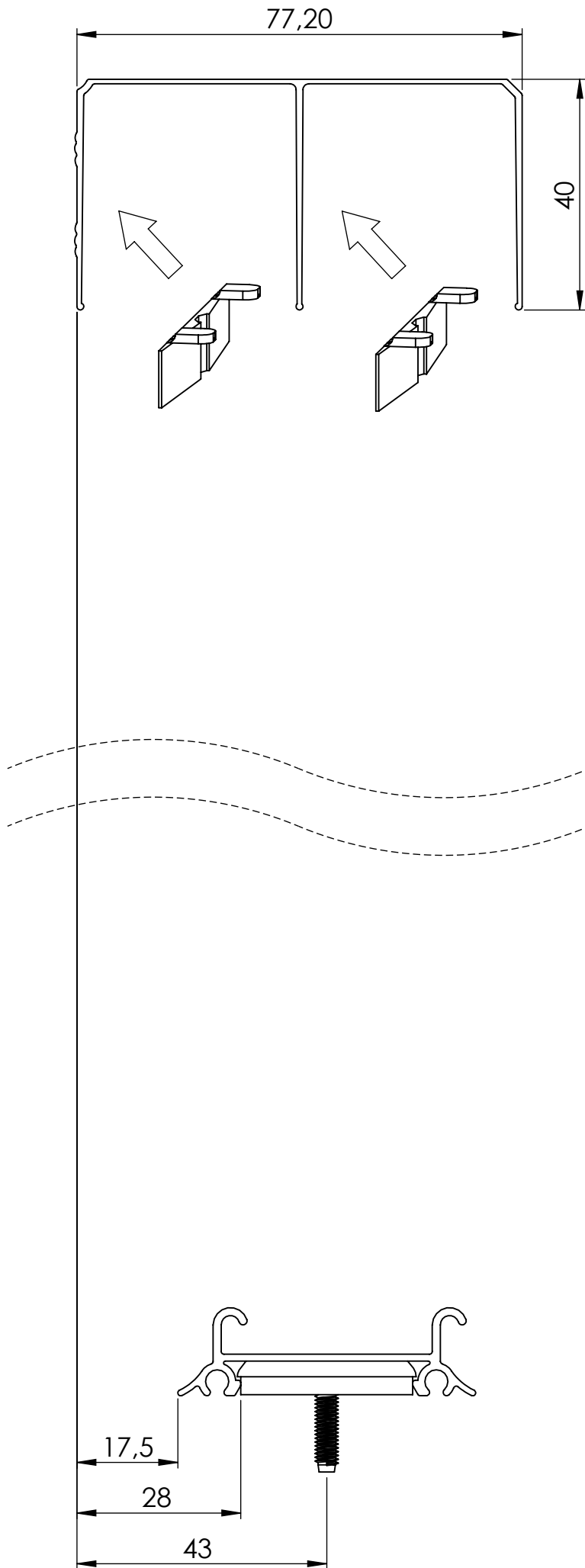

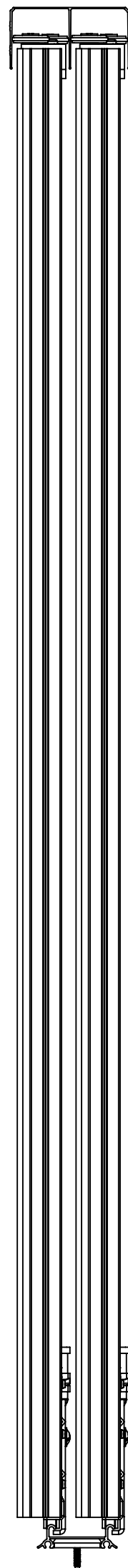
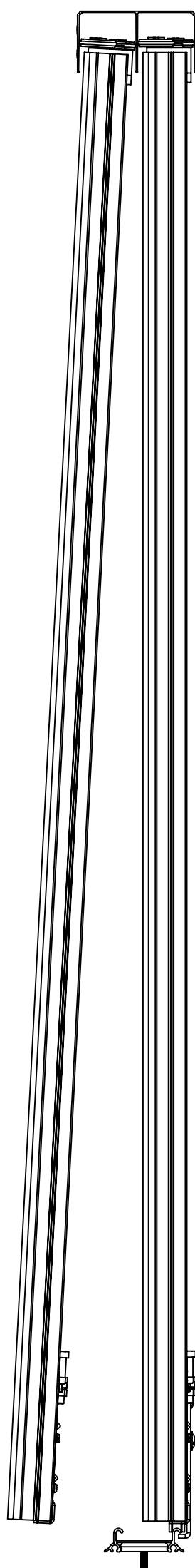
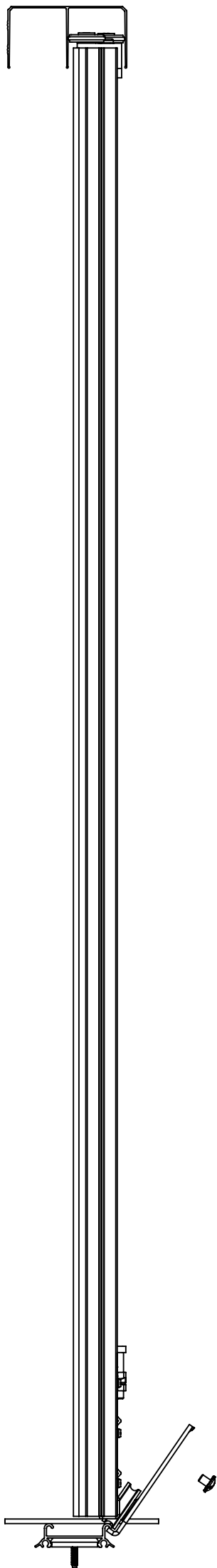
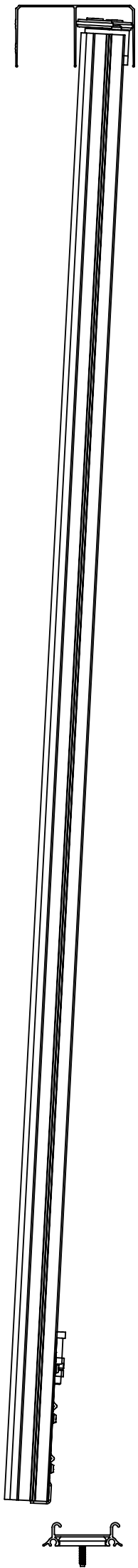

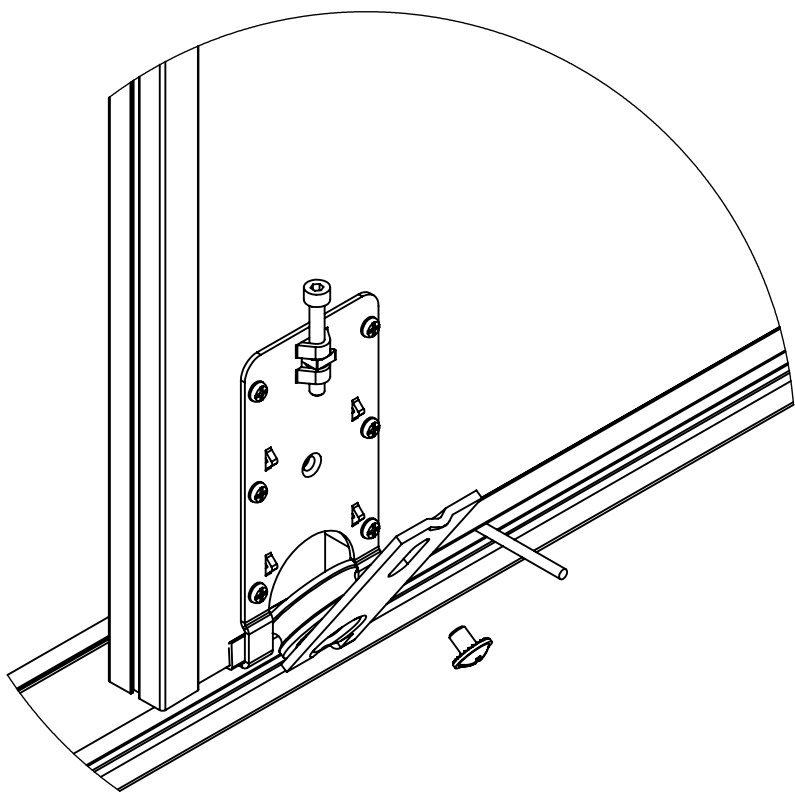

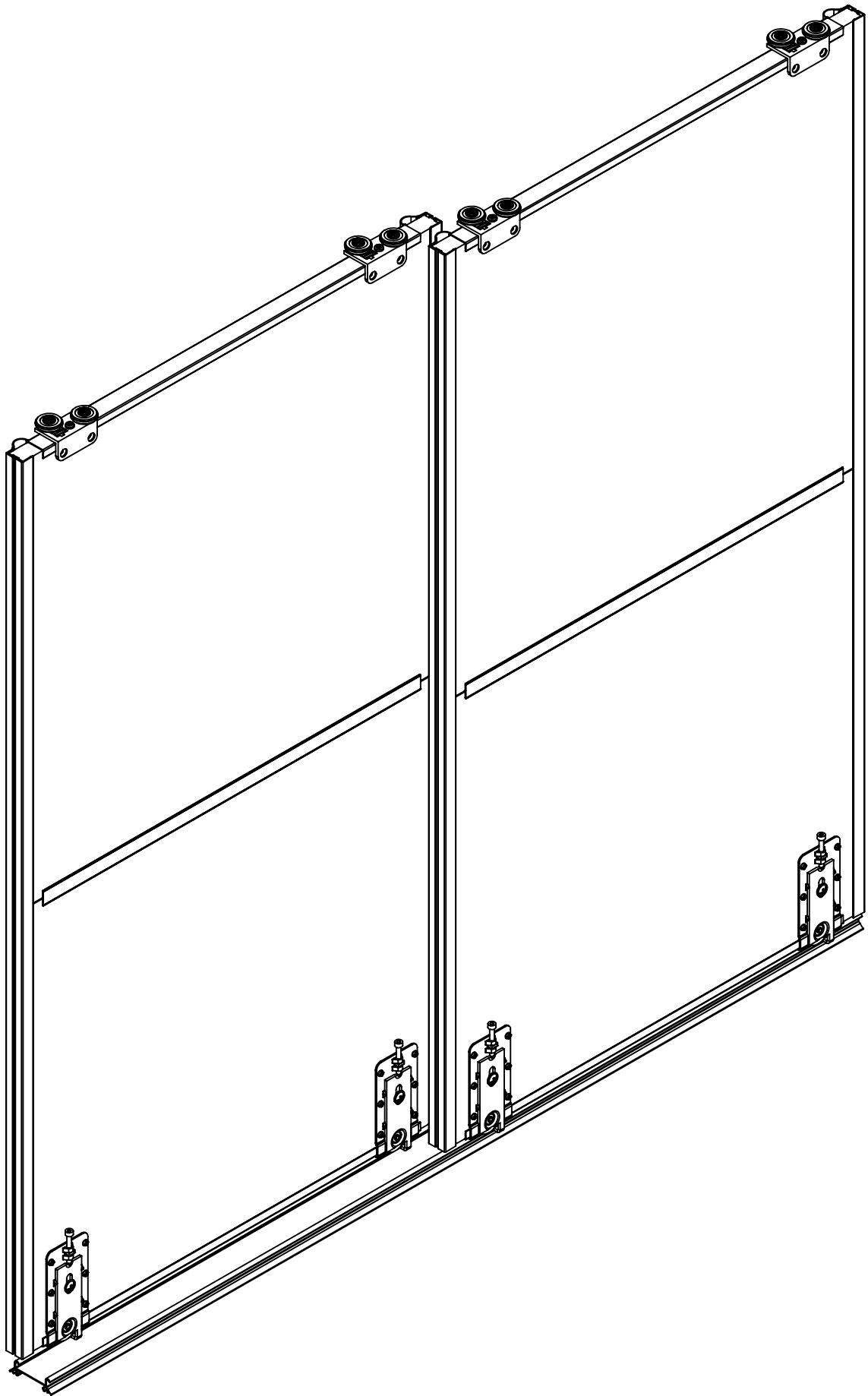

System z rączką OMEGA BRUSH na torze dolnym GAMA i górnym UNIWERSALNYM z okuciem SLIM. System with handle OMEGA BRUSH, with lower track GAMA and UNIVERSAL upper track with hardware SLIM.

PŁYTA BOARD 18 mm	liczba skrzydeł drzwi quantity of doors n	n=2	n=3	n=4	n=5	n=6	n=7	n=8
	wysokość płyty board height h _p	h _p =H-49						
	szerokość płyty board width b _p	$b_p = \frac{S+23}{2}$	$b_p = \frac{S+52}{3}$	$b_p = \frac{S+81}{4}$	$b_p = \frac{S+110}{5}$	$b_p = \frac{S+139}{6}$	$b_p = \frac{S+168}{7}$	$b_p = \frac{S+198}{8}$
	długość ceownika dolnego, górnego oraz łącznika upper, lower C- profile and connector lenght R	R=b _p -46						
	długość rączki handle lenght L _R	L _R =H-47						
