

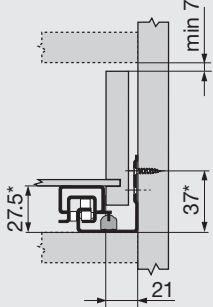

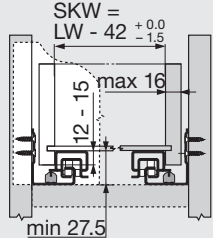
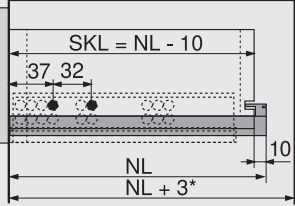
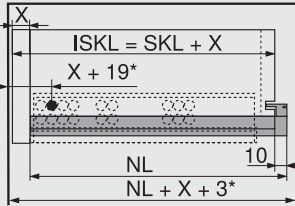
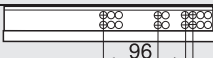

TANDEM plus BLUMOTION – 560H/566H

Projektovanie

Potreba miesta v korpuse	Zásuvka/vnútná zásuvka	Zásuvka	Vnútná zásuvka
* + 3 mm s bočnou stabilizáciou	SKW Svetlá šírka zásuvky LW Svetlá šírka korpusu	SKL Dĺžka zásuvky NL Menovitá dĺžka * Navyše + 12 mm s bočnou stabilizáciou	ISKL Vnútná dĺžka zásuvky SKL Dĺžka zásuvky NL Menovitá dĺžka * Navyše + 2 mm s POSISTOP
			

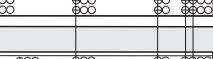
Poloha upevnenia korpusových líšt skrutkami

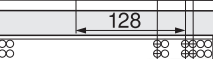
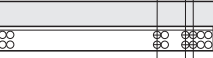
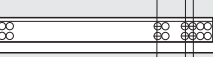
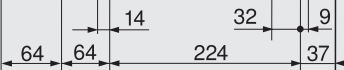
Menovitá dĺžka NL (mm)	Diagram
250, 270	
300, 320	
350, 380	
400, 420	
450, 480	
500 - 550	
580, 600	
650 - 750	

Spracovanie zásuviek

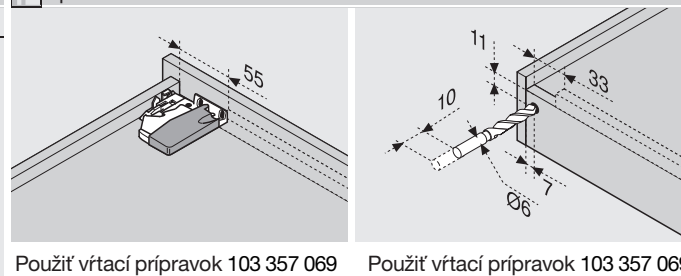

Použiť vrtací prípravok 103 357 069

Použiť vrtací prípravok 103 357 069

Upozornenie na strany

Prehľad – TANDEM	473
Prehľad – SERVO-DRIVE na MOVENTO/TANDEM	505
Prehľad – ORGA-LINE na MOVENTO/TANDEM	583
Príslušenstvo	494
Upevnenie korpusových líšt	500
Montáž, demontáž a nastavenie	502
Prehľad – pomôcky na spracovanie	605
Ďalšie technické informácie	684